

# PAUL WURTH

SMS group

## Valves for Dehydrogenation

Oil & Gas Downstream Processes



Taking advantage of its long-standing know-how in designing and supplying special valves for severe operating conditions for metallurgical plants like blast furnaces, the Paul Wurth Oil & Gas division today develops, manufactures and distributes special valve solutions for refineries and petrochemical plants.

### Wedge-within-Wedge type Isolation Gate Valves

In the field of **Dehydrogenation**, Paul Wurth offers Wedge-within-Wedge type Isolation Gate Valves tailored to your needs.

The Wedge-within-Wedge type Gate Valve is designed for extreme tight isolation under severe

operation conditions of high temperature, unequal temperature distribution, high pressure and high line stresses. In addition its design allows a high frequency of operation and an easy, low-friction actuation in opening as well as in closing direction.

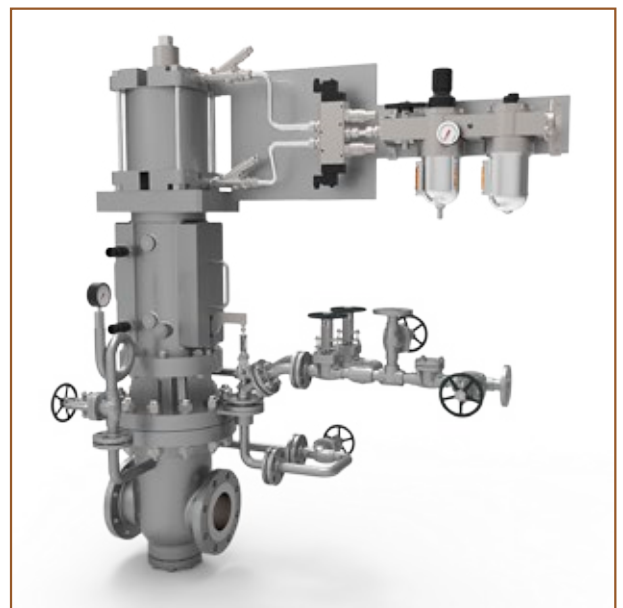
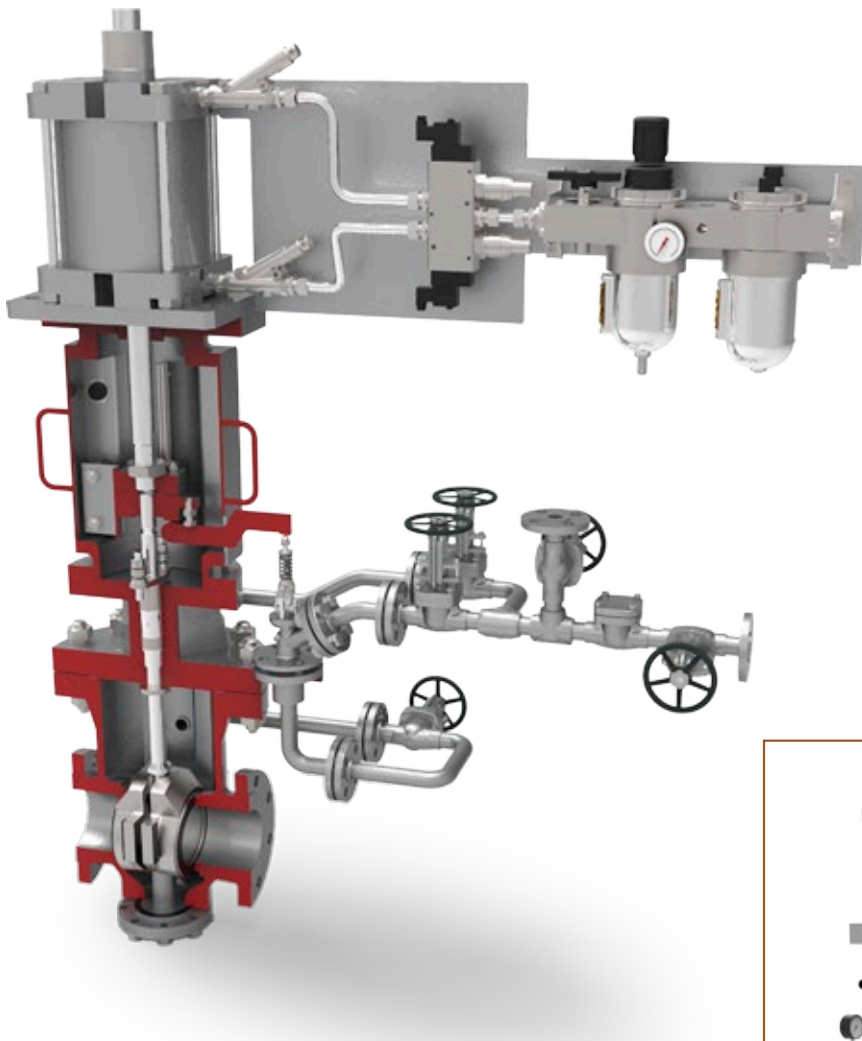

## Key features

- ▶ Double Disc Technology provides positive, tight shut-off by means of active sealing force when shut
- ▶ Double Block and Purge or Double Block and Bleed performance within one valve body
- ▶ High tightness, no jamming or blocking of the valve even under severe temperature differences by means of double wedge design
- ▶ No wear of sealing surfaces due to axial pressing in closed position
- ▶ Valve available in casted design as well as fabricated design, according to customer demands and licensors/customers specifications
- ▶ Electrical, hydraulic or pneumatic options available for valve actuation
- ▶ Paul Wurth provides system package comprising Valves, Hydraulic Power Station, Hydraulic manifolds and PLC control system out of one hand



## Typical Figures

- ▶ size from 10" up to 80"
- ▶ operating temperature up to 700°C
- ▶ operating pressure up to 10 bar(g)
- ▶ actuation: electric, pneumatic, hydraulic

**Other sizes, design features and/or operating features are available on request.**



# Engineering & Technology worldwide

The Paul Wurth Group is today one of the world leaders in the design and supply of complete plants, systems and processes as well as specialised mechanical equipment for

## ■ the iron & steel industry:

Blast Furnaces & Auxiliary Plants  
Coke Making Plants  
Agglomeration Plants  
Direct Reduction Plants  
Environmental Protection, Recycling & Energy-Saving Technologies

## ■ other industries:

Valve Solutions for Oil & Gas Downstream Processes  
Solutions for Decentralised Energy Production  
Intralogistics Solutions for Heavy Loads  
Engineering & Project Management for Civil Construction and Infrastructure Projects

**Feasibility Studies – Conceptual, Basic and Detail Engineering – Project Management – Plant and Components Supply – Turnkey Projects – Assistance in Plant Assembly and Commissioning – Technology and Operations Consultancy – On-site and Remote Operational Assistance – After-sales Services**

© Copyright 2017 Paul Wurth S.A. – all rights reserved

**Non Contractual Data:** Paul Wurth believes that the data contained in this folder are correct and accurate, but cannot guarantee same or better performances for any specific site without a detailed quote. **Patents and Patents pending.** — Paul Wurth equipment and processes are protected in many countries by patents.

Paul Wurth and the Paul Wurth Logo are trademarks of Paul Wurth S.A. and may be registered in your jurisdiction.



# PAUL WURTH

SMS group

oil-gas@paulwurth.com • www.paulwurth.com

### Paul Wurth Deutschland GmbH

Paul Wurth Oil & Gas Division  
Mönchengladbach, GERMANY  
Phone: (+49) 2161 4785824  
oil-gas@paulwurth.com

### EUROPE

#### Paul Wurth S.A.

Luxembourg, LUXEMBOURG  
Phone: (+352) 4970-1  
paulwurth@paulwurth.com

#### Paul Wurth Italia S.p.A.

Genoa, ITALY  
Phone: (+39) 010 640 91  
pwit@paulwurth.com

#### Paul Wurth Deutschland GmbH

Essen, GERMANY  
Phone: (+49) 201 245300  
pwdeutschland@paulwurth.com

#### Mainz-Kastel, GERMANY

Phone: (+49) 6134 606 6  
pwdeutschland@paulwurth.com

#### Mönchengladbach, GERMANY

Phone: (+49) 2161 4785824  
oil-gas@paulwurth.com

#### Paul Wurth, a.s.

Ostrava, CZECH REPUBLIC  
Phone: (+420) 595 155 100  
pwcz@paulwurth.com

### Paul Wurth Moscow Representation Office

Moscow, RUSSIA  
Phone: (+7) 495 721 1553  
pwmoscow@paulwurth.com

### Paul Wurth Kovrov

Kovrov, Vladimir region, RUSSIA  
Phone: (+7) 49232 97099  
pwkovrov@paulwurth.com

### Paul Wurth Metallurgical Services LLC

Cheliabinsk, RUSSIA  
Phone: (+7) 351 799 60 60  
pwms@paulwurth.com

### Paul Wurth Ukraine Representation Office

Mariupol, UKRAINE  
Phone: (+380) 629 41 18 99  
pwua@paulwurth.com

### Paul Wurth International Site Services S.r.l

Genoa, ITALY  
Phone: (+39) 010 640 9700  
pwis@is.paulwurth.com

Joint company of  
Dango & Dienenthal and  
Paul Wurth:

**TMT – Tapping Measuring Technology**  
Luxembourg, LUXEMBOURG  
Phone: (+352) 261920 0

Siegen, GERMANY  
Phone: (+49) 271 4014 0  
contact@tmt.com •  
www.tmt.com

Joint Company of  
SAB and Paul Wurth:

**VCL – Valve Competence Luxembourg**  
Grevenmacher, LUXEMBOURG  
Phone: (+352) 27 68 54  
info@vcl.lu • www.vcl.lu

Joint company of  
SMS group and Paul Wurth

**AMOVA**  
Lentzweiler, LUXEMBOURG  
Phone: (+352) 2685 2000

Netphen, GERMANY  
Phone: (+49) 2738 21 0  
info@amova.eu • www.amova.eu

### AMERICAS

#### Paul Wurth Inc.

Valparaiso, Indiana, USA  
Phone: (+1) 219 756 1061  
pwus@paulwurth.com

#### Paul Wurth do Brasil

Belo Horizonte, M.G., BRAZIL  
Phone: (+55) 31 3228 2800  
pwbr@paulwurth.com

#### Paul Wurth do Brasil Montagens e Manutenção Ltda

Vespasiano, M.G. BRAZIL  
Phone: (+55) 31 3228 2799  
pwbm@paulwurth.com

#### Paul Wurth de Mexico SA de CV

Atizapan, MEXICO  
Phone: (+52) 55 1106 3463  
pwmx@paulwurth.com

### ASIA

#### Paul Wurth Metal Technology (Beijing) Co., Ltd

Beijing, P.R. CHINA  
Phone: (+86) 10 8405 4400  
pwbeijing@paulwurth.com

#### Beijing Paul Wurth Trading Co., Ltd

Beijing, P.R. CHINA  
Phone: (+86) 10 8405 4699  
china.trading@paulwurth.com

### Shanghai Paul Wurth Metallurgical Equipment Manufacture Co., Ltd

Shanghai City, CHINA  
Phone: (+86) 21 61186300  
pwwshanghai@paulwurth.com

### Paul Wurth India Pvt. Ltd

Gurgaon, INDIA  
Phone: (+91) 124 4523200  
pwindia@paulwurth.com

### Paul Wurth International S.A. Taiwan Branch

Kaohsiung, TAIWAN  
Phone: (+886) 7 33 93 309  
pwtaiwan@paulwurth.com

### Paul Wurth International S.A. Korea Branch

Seoul, KOREA  
Phone: (+82) 2 553 9450  
pwkorea@paulwurth.com

### Paul Wurth Vietnam Co., Ltd

Ho Chi Minh City, VIETNAM  
Phone: (+84) 8 73 000 514  
pwwvietnam@paulwurth.com

Joint company of  
IHI Corporation and Paul Wurth:

### PAUL WURTH IHI Co., Ltd.

Tokyo, JAPAN  
Phone: (+81) 3 6630 4785  
contact@ihi-pw.jp